

3D-Tool

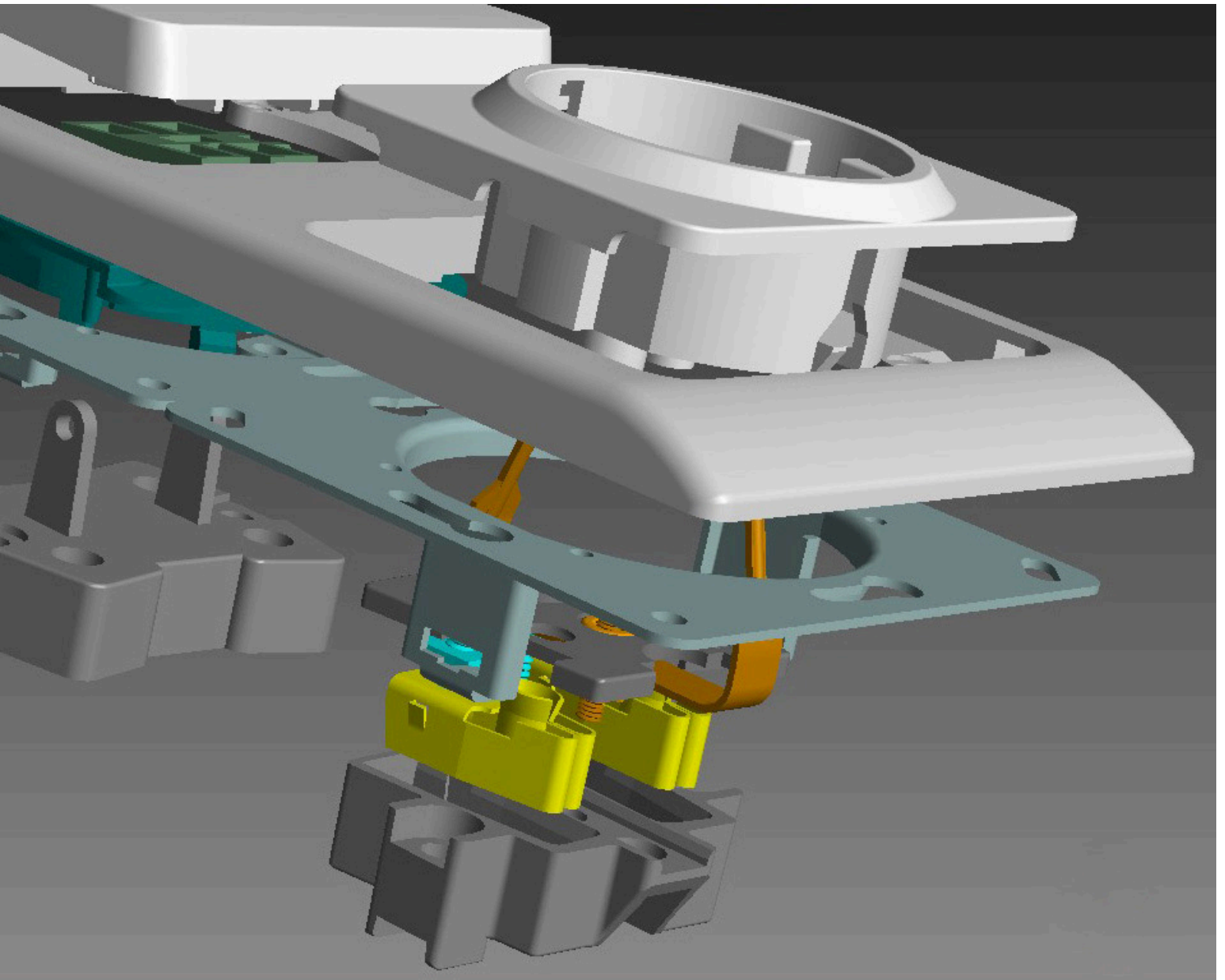

3D-Tool is a leading provider of stand-alone 3D model viewing and analysis software



Market:
3D/2D CAD viewing, translation and collaboration software

Product:
3D InterOp

CHALLENGES

Meet customer requirements to work with native CAD file formats within 3D-Tool CAD Viewer

Solutions:

3D InterOp file format translation selected based on:

- High quality translation and performance
- Competent and reliable technical support ensured quick and easy implementation
- Flexible licensing and cost structure supported 3D-Tool's existing licensing model and price point

Results:

- Immediate customer uptake to enhanced 3D-Tool CAD Viewer in terms of upgrades and acquisition of new customers, increasing 3D-Tool year-over-year revenues by more than 30 percent
- New ability to view and analyze parts and assemblies in native CAD format streamlines customer workflow processes – often critical to success

COMPANY

3D-Tool provides a professional, easy-to-use and cost-effective CAD viewer and converter with a wide range of functionality to communicate 3D designs across the project team and with stakeholders, customers and others in need of a sophisticated design review. The product includes native CAD translation options to exchange CAD data between different CAD programs. Located in Heddeshheim, Germany, since 2000 3D-Tool has helped customers accelerate and simplify the review of CAD data. The 3D-Tool company policy is to provide the highest usability and functionality based on users' needs at an affordable price.

3D-Tool is designed to view and analyze 3D models without expensive CAD software or CAD knowledge. During the last decade the product has evolved from a pure 3D viewer to a professional CAD analysis and collaboration tool, offering numerous features to review and analyze 3D geometry. Measuring tools, dynamic cross sections and exploded views provide a detailed view of the design. The high quality display and the intuitive interface make it easy for users to see interfering parts and other construction errors. Information about volumes, surfaces, draft angles, projected areas and wall thicknesses complete the features.

3D-Tool is also used to publish CAD data in 3D-Tool or 3D PDF format without additional licensing cost. Complete projects can be published to directly executable files containing all 3D/2D CAD data, all user-defined dimensions and markups and the full functional 3D-Tool Viewer. With this feature, every member of the project team, from engineering to marketing, as well as

customers and suppliers, can evaluate designs in 3D; accelerating and improving the decision and approval process while avoiding expensive mistakes.

"Throughout the entire implementation process the Spatial team turned out to be exactly the partner we expected."

-- Frank Nagel 3D-Tool Customer Support

CHALLENGE

3D-Tool already offered almost 20 different 3D and 2D CAD file formats, making it possible to use 3D-Tool with every CAD system because each exported at least one of 3D-Tool's supported formats. However, there were no interfaces for native formats available for the direct review of 3D models out of major CAD programs such as CATIA V5 and Pro/Engineer®. The need to use a 3D exchange format such as STEP or IGES limited the usability of 3D-Tool in certain circumstances.

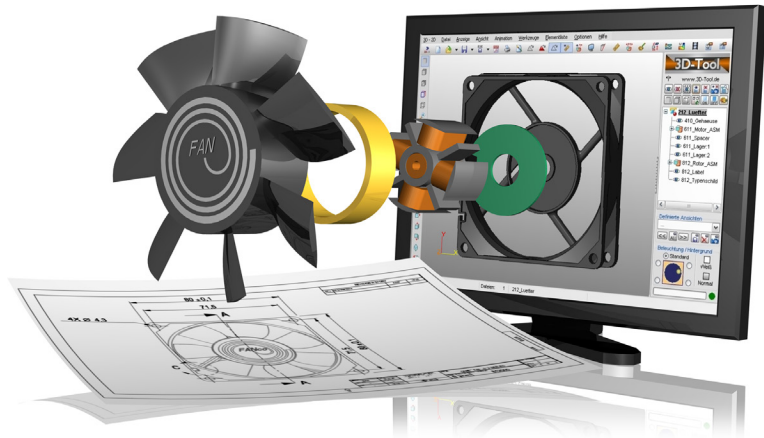

Some, especially smaller, companies do not have access to a CAD system and/or do not have influence on the type of CAD data to be reviewed. Often they are forced to take what they can get – e.g., CATIA V5 in the automotive sector.

And even if there is a CAD system present, CAD seats are limited and conversion to exchange formats takes time and often experience. In addition not all CAD programs can import native files from other CAD programs. And even if there are such interfaces available, they are quite expensive.

3D-Tool sought a way to expand the 3D-Tool Viewer functionality to native CAD formats such as CATIA V5 and Pro/E, enabling users to view native CAD files without the need of conversion. This capability would enable users to translate native CAD files to a file format supported by their CAD program. It was imperative to accomplish this without making it cost prohibitive to its customers.

SOLUTION

After evaluating several options for its native CAD viewing and translation needs, the 3D-Tool team selected Spatial 3D InterOp components to accomplish this task. The decision was based on a number of factors. Tests demonstrated a high translation quality and fast performance. In addition, the team determined that Spatial offered competent and reliable technical support and documentation, which made it likely that implementation of the new interfaces would be accomplished easily and quickly. "Equally important was the fact that Spatial offers a licensing and cost structure which fits perfectly with our existing licensing model and with our ideas about a good target price for our new product," says Frank Nagel, 3D-Tool Customer Support.

The implementation of the 3D InterOp components was accomplished without problems in just four months. "Throughout the entire implementation process the Spatial team turned out to be exactly the partner we expected," added Nagel.

The new product is called 3D-Tool Premium Version, and features a 3D Tool CAD-Viewer with native interfaces for CATIA V5, CATIA V4, Pro/E and Autodesk Inventor® plus 18 additional 3D and 2D CAD interfaces. The product also includes a 3D-NativeCAD Converter that translates CATIA V5/V4, Pro/E, Inventor, STEP, IGES, VDA, SAT to CATIA V5/V4, STEP, IGES, VDA, SAT and STL.

RESULTS

Customers using CATIA V5/V4, Pro/E or Autodesk Inventor now use the 3D-Tool Viewer to directly view and analyze parts and assemblies out of these programs without the need to convert them first to a 3D exchange format supported by 3D-Tool. This makes it easier to include all "non-CAD" members of a project team in the product development process.

Customers receiving native CATIA V5/V4, Pro/E or Autodesk Inventor files but without the attendant programs/interfaces can now view and analyze these files without the need to ask their partners for a common exchange format. This saves time, prevents partners from getting annoyed and especially conveys competence.

The new 3D-NativeCAD Converter with its ability to translate native CAD files to common 3D exchange formats added a new dimension to the usability of 3D-Tool. Now users can convert 3D CAD data to be used with their existing CAD programs.

After releasing 3D-Tool Premium with its ability to view and convert native CAD files, the 3D-Tool team has noted the following results:

- A noticeable amount of existing customers immediately upgraded their 3D-Tool licenses to the new Premium Version
- A sizeable increase in product inquiries and trial licenses
- Many new Premium customers
- The customer feedback concerning the quality and speed of translation was thoroughly positive

Our 3DEXPERIENCE platform powers our brand applications, serving 12 industries, and provides a rich portfolio of industry solution experiences.

Dassault Systèmes, the 3DEXPERIENCE Company, provides business and people with virtual universes to imagine sustainable innovations. Its world-leading solutions transform the way products are designed, produced, and supported. Dassault Systèmes' collaborative solutions foster social innovation, expanding possibilities for the virtual world to improve the real world. The group brings value to over 170,000 customers of all sizes in all industries in more than 140 countries. For more information, visit www.3ds.com.



3DEXPERIENCE
